



NUREMS

İÇ ve DIŞ TİCARET • IMPORT and EXPORT



SİLİNDİR ÖLÇÜSÜ (mm)		SİSTEM BASINCI(bar)	100	120	140	160	180	200	250	300
Boru Çapı	Mil Çapı	ALINAN KUVVET	Kg	Kg	Kg	Kg	Kg	Kg	Kg	Kg
35x45	22	İtme/Pushing	962	1.155	1.347	1.539	1.732	1.924	2.405	2.886
		Çekme/Pulling	582	698	815	931	1.048	1.164	1.455	1.746
40x50	25	İtme/Pushing	1.257	1.508	1.759	2.011	2.262	2.513	3.142	3.770
		Çekme/Pulling	766	919	1.072	1.225	1.378	1.532	1.914	2.297
45x55	25	İtme/Pushing	1.590	1.909	2.227	2.545	2.863	3.181	3.976	4.771
		Çekme/Pulling	1.100	1.319	1.539	1.759	1.979	2.199	2.749	3.299
50x60	30	İtme/Pushing	1.963	2.356	2.749	3.142	3.534	3.927	4.909	5.890
		Çekme/Pulling	1.257	1.508	1.759	2.011	2.262	2.513	3.142	3.770
55x65	35	İtme/Pushing	2.376	2.851	3.326	3.801	4.276	4.752	5.940	7.227
		Çekme/Pulling	1.414	1.696	1.979	2.262	2.545	2.827	3.534	4.241
60x70	40	İtme/Pushing	2.827	3.393	3.958	4.524	5.089	5.655	7.069	8.482
		Çekme/Pulling	1.571	1.885	2.199	2.513	2.827	3.142	3.927	4.712
63x75	40	İtme/Pushing	3.117	3.741	4.364	4.988	5.611	6.234	7.793	9.352
		Çekme/Pulling	1.861	2.233	2.605	2.977	3.349	3.721	4.652	5.582
65x75	40	İtme/Pushing	3.318	3.982	4.646	5.309	5.973	6.637	8.296	9.955
		Çekme/Pulling	2.062	2.474	2.886	3.299	3.711	4.123	5.154	6.185
70x80	50	İtme/Pushing	3.848	4.618	5.388	6.158	6.927	7.697	9.621	11.545
		Çekme/Pulling	1.885	2.262	2.639	3.016	3.393	3.770	4.712	5.655
75x85	50	İtme/Pushing	4.418	5.301	6.185	7.069	7.952	8.836	11.045	13.254
		Çekme/Pulling	2.454	2.945	3.436	3.927	4.418	4.909	6.136	7.363
80x95	50	İtme/Pushing	5.027	6.032	7.037	8.042	9.048	10.053	12.566	15.080
		Çekme/Pulling	3.063	3.676	4.288	4.901	5.513	6.126	7.658	9.189
85x100	50	İtme/Pushing	5.674	6.809	7.944	9.079	10.214	11.349	14.186	17.023
		Çekme/Pulling	3.711	4.453	5.195	5.938	6.680	7.422	9.278	11.133
90x105	60	İtme/Pushing	6.362	7.634	8.906	10.179	11.451	12.723	15.904	19.085
		Çekme/Pulling	3.534	4.241	4.948	5.655	6.362	7.069	8.836	10.603
100x115	70	İtme/Pushing	7.854	9.425	10.996	12.566	14.137	15.708	19.635	23.562
		Çekme/Pulling	4.006	4.807	5.608	6.409	7.210	8.011	10.014	12.017
110x130	70	İtme/Pushing	9.503	11.404	13.305	15.205	17.106	19.007	23.758	28.510
		Çekme/Pulling	5.655	6.786	7.917	9.048	10.179	11.310	14.137	16.965
120x140	80	İtme/Pushing	11.310	13.572	15.834	18.096	20.258	22.619	28.274	33.929
		Çekme/Pulling	6.283	7.540	8.796	10.053	11.310	12.566	15.708	18.850
125x145	80	İtme/Pushing	12.272	14.726	17.181	19.635	22.089	24.544	30.680	36.816
		Çekme/Pulling	7.245	8.694	10.143	11.592	13.042	14.491	18.113	21.736
130x150	80	İtme/Pushing	13.273	15.928	18.583	21.237	23.892	26.546	33.183	39.820
		Çekme/Pulling	8.247	9.896	11.545	13.195	14.844	16.493	20.617	24.740
140x160	80	İtme/Pushing	15.394	18.473	21.551	24.630	27.709	30.788	38.484	46.181
		Çekme/Pulling	10.367	12.441	14.514	16.588	18.661	20.734	25.918	31.102
150x170	90	İtme/Pushing	17.671	21.206	24.740	28.274	31.809	35.343	44.179	53.014
		Çekme/Pulling	11.310	13.572	15.834	18.096	20.358	22.619	28.274	33.929
160x180	90	İtme/Pushing	20.106	24.127	28.149	32.170	36.191	40.212	50.265	60.319
		Çekme/Pulling	13.744	16.493	19.242	21.991	24.740	27.489	34.361	41.233



İlaçlama Makinesi / Spraying machine

Pipe: 38 x 48
Shaft: 25 mm
Hole Center: 770 mm
Stroke: 610 mm



Hidrolik Kaydırmalı Rotovator
Hydraulic Shift of Rotovator

Pipe: 40 x 50
Shaft: 25 mm
Hole Center: 565 mm
Stroke: 470 mm



Silaj Makinesi / Silage Machines

Pipe: 50 x 60
Shaft: 32 mm
Hole Center: 390 mm
Stroke: 220 mm



Gübre Serpme Makinesi
Fertilizer Spreader

Pipe: 38 x 48
Shaft: 25 mm
Hole Center: 280 mm
Stroke: 130 mm



Kaynak Otomasyon
Welding Automation

Pipe: 32 x 40
Shaft: 20 mm
Hole Center: 420 mm
Stroke: 190 mm



Dorse Tentenelerini Açma Kapı
Trailer Tent Opening System

Pipe: 32 x 40
Shaft: 20 mm
Hole Center: 600 mm
Stroke: 410 mm



Silaj Makinesi / Silage Machines

Pipe: 32 x 40
Shaft: 20 mm
Hole Center: 400 mm
Stroke: 230 mm



Briket Makinesi / Briquettes Machine

Pipe: 50 x 60
Shaft: 30 mm
Hole Center: 580 mm
Stroke: 470 mm



Silaj Makinesi / Silage Machines

Pipe: 32 x 40
Shaft: 20 mm
Hole Center: 260 mm
Stroke: 115 mm

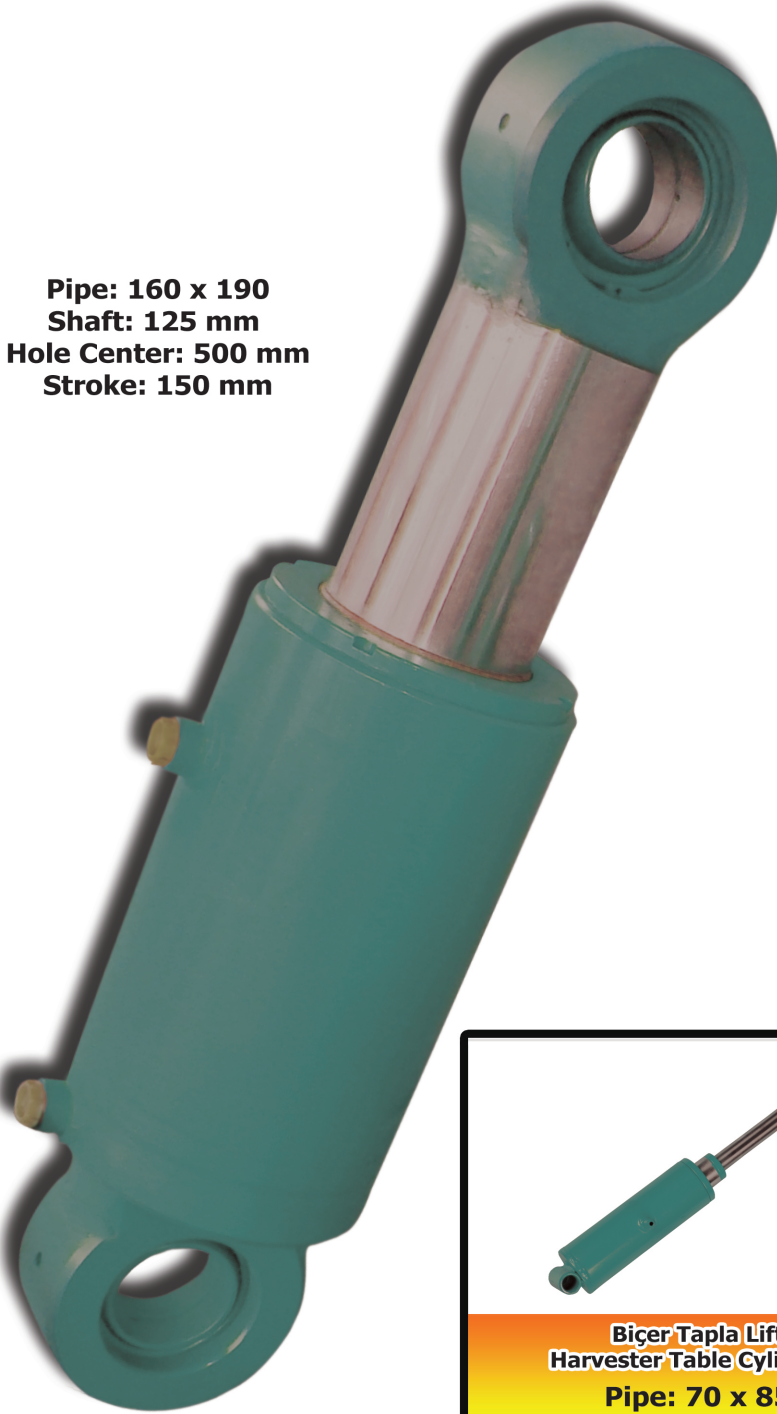

Pipe: 160 x 190
Shaft: 125 mm
Hole Center: 500 mm
Stroke: 150 mm



Ahtapot Makinesi / Octopus Machine

Pipe: 63 x 75
Shaft: 45 mm
Hole Center: 410 mm
Stroke: 230 mm



Mibzer / Seeder

Pipe: 50 x 60
Shaft: 32 mm
Hole Center: 310 mm
Stroke: 120 mm



Biçer Tapla Lifti
Harvester Table Cylinder

Pipe: 70 x 85
Shaft: 40x50 mm
Hole Center: 30 mm
Stroke: 420 mm



Hidrolik Direksiyon / Hydraulic Wheel

Pipe: 32 x 40
Shaft: 20 mm
Hole Center: 530 mm
Stroke: 160 mm





Pipe: 63 x 75
Shaft: 45 mm
Hole Center: 950 mm
Stroke: 850 mm

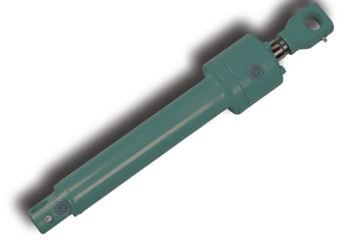
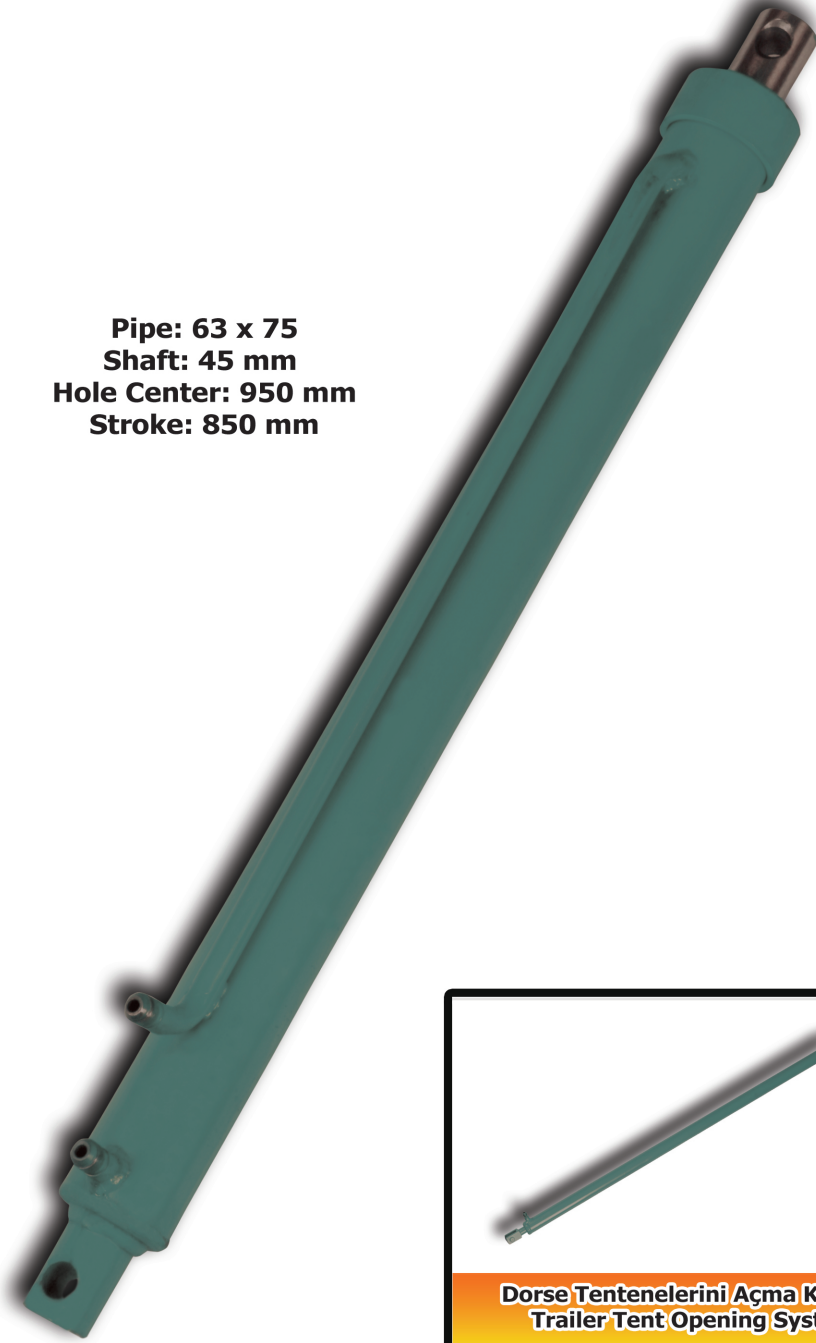

Şok Lifti / Shock Cylinder

Pipe: 50 x 60
Shaft: 40 mm
Hole Center: 620 mm
Stroke: 350 mm

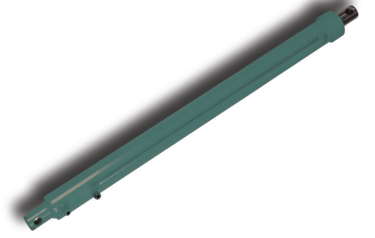

**Ahtapot Bom Lifti
Octopus Lifting Cylinder**

Pipe: 63 x 75
Shaft: 45 mm
Hole Center: 1100 mm
Stroke: 950 mm

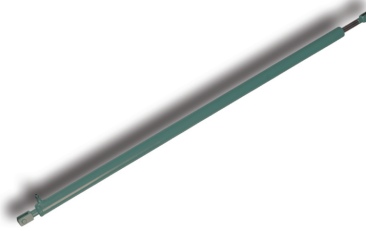

**Dorse Tentenelerini Açma Kapı
Trailer Tent Opening System**

Pipe: 32 x 40
Shaft: 20 mm
Hole Center: 1300 mm
Stroke: 1100 mm

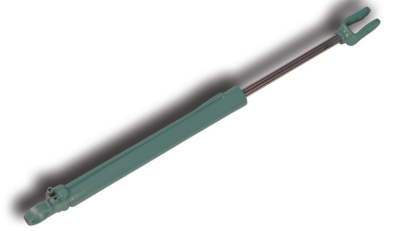

**Isuzu Kamyon Kabin Lifti
Isuzu Truck Cabinet Cylinder**

Pipe: 50 x 60
Shaft: 32 mm
Hole Center: 600 mm
Stroke: 480 mm



NUREMIS
İÇ VE DIŞ TİCARET • İMPORT and EXPORT
Our Sectors
www.nurems.com.tr





NUREMS Import & Export
Yazır Mahallesi, Şafak Cd. 10/C, 42130 Selçuklu/Konya, Türkiye
Tel. +90 332 261 1031 Fax. +90 332 261 10 32
Url. www.nurems.com.tr E-mail : info@nurems.com.tr